

TEST PRESSURE

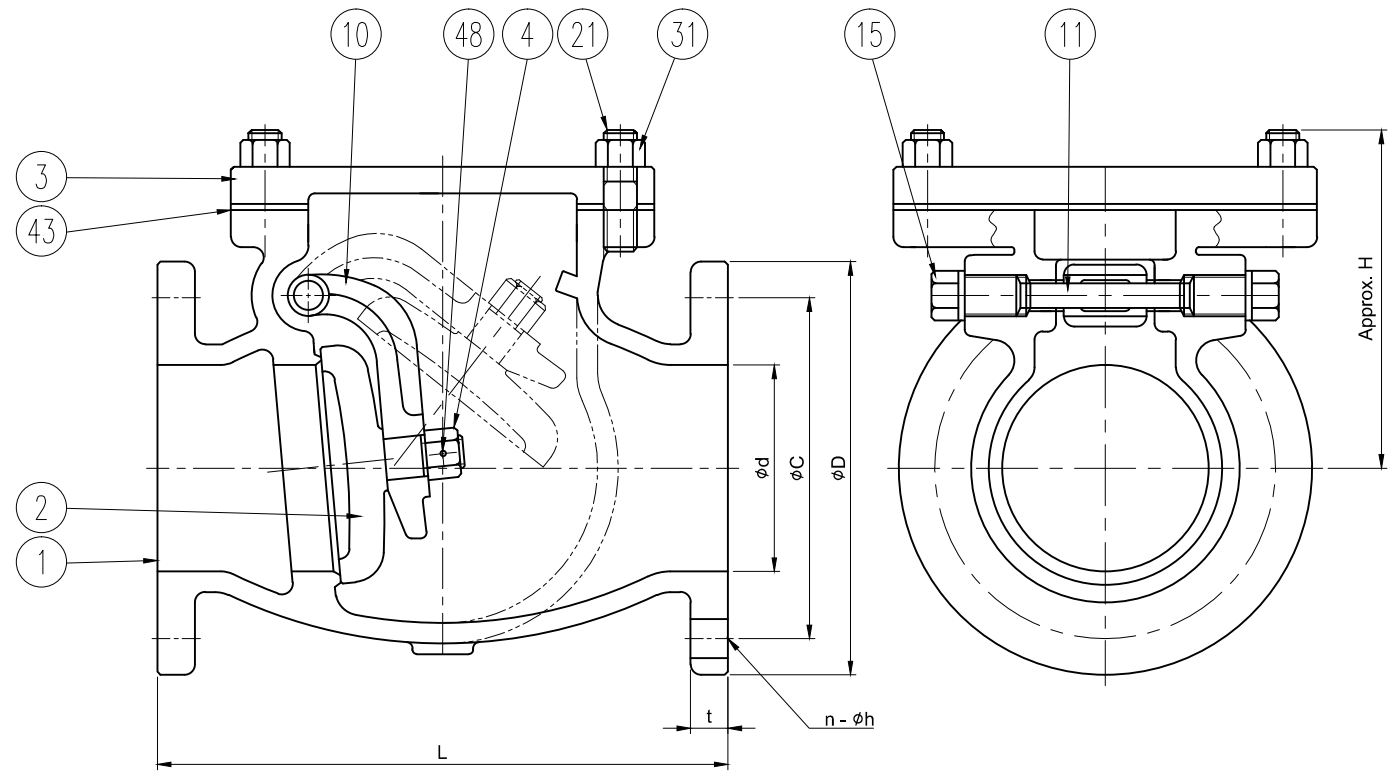

HYDRAULIC TEST		kgf/cm <sup>2</sup>	psi
	SHELL	24.6	350
	SEAT	15.8	225



NOTES

- \* Applicable Standard
- 1. Valve standard & Code : ASME B16.24
- 2. Face to Face : ASME B16.10
- 3. Flange Dimension : ASME B16.24, FF
- 4. Inspection & Test : API 598
- 5. Country of Origin : Korea

NO.	PART NAME	MATERIAL	REMARKS
48	COTTER PIN	B124 - C37700	
43	GASKET	NON - ASBESTOS	
31	COVER NUT	B124 - C37700	
21	COVER BOLT	B124 - C37700	
15	SIDE PLUG	B124 - C37700	
11	HINGE PIN	B150 - C63000	
10	HINGE ARM	B62 - C83600	
4	DISC NUT	B150 - C63000	
3	COVER	B62 - C83600	
2	DISC	B62 - C83600	
1	BODY	B62 - C83600	

[ Unit : mm ]

NPS	BORE ød	FLANGE ASME 150lbs FF					L	H
		øD	øC	t	n	øh		
2"	50.8	150	120.7	12.7	4	19	203	135
2½"	63.5	180	139.7	14.2	4	19	216	150
3"	76.2	190	152.4	15.7	4	19	241	160
4"	101.6	230	190.5	17.5	8	19	292	180
5"	127	255	215.9	19.1	8	22	330	200
6"	152.4	280	241.3	20.6	8	22	356	210
8"	203.2	345	298.5	23.9	8	22	495	260
10"	254	405	362.0	25.4	12	25	622	310
12"	304.8	485	431.8	26.9	12	25	698	320

REV. NO.	DATE	DESCRIPTION	DRW'D BY	CHK'D BY	APP'D BY
△					
△	2020.11.03	Material changed	J.S.LIM	S.K.CHOI	H.Y.JUNG
△	2019.07.10	Material changed	J.S.LIM	H.Y.JUNG	S.H.AHN

TITLE		CAST BRONZE SWING CHECK VALVE				
RATING	Class 150		SIZE	See Table	UNIT	mm
DRW'D BY	CHK'D BY	APP'D BY	DATE	2017.05.30	SCALE	N / S
J.S.LIM	H.Y.JUNG	S.H.AHN	TYPE	Bolted Cover		
			DWG. NO.	SWV - BC - 150P - 2.0 - 12B		
SPACE FIG NO.		15055 - B				