

TEST PRESSURE

HYDRAULIC TEST		kgf/cm ²	psi
	SHELL	24.6	350
	SEAT	15.8	225

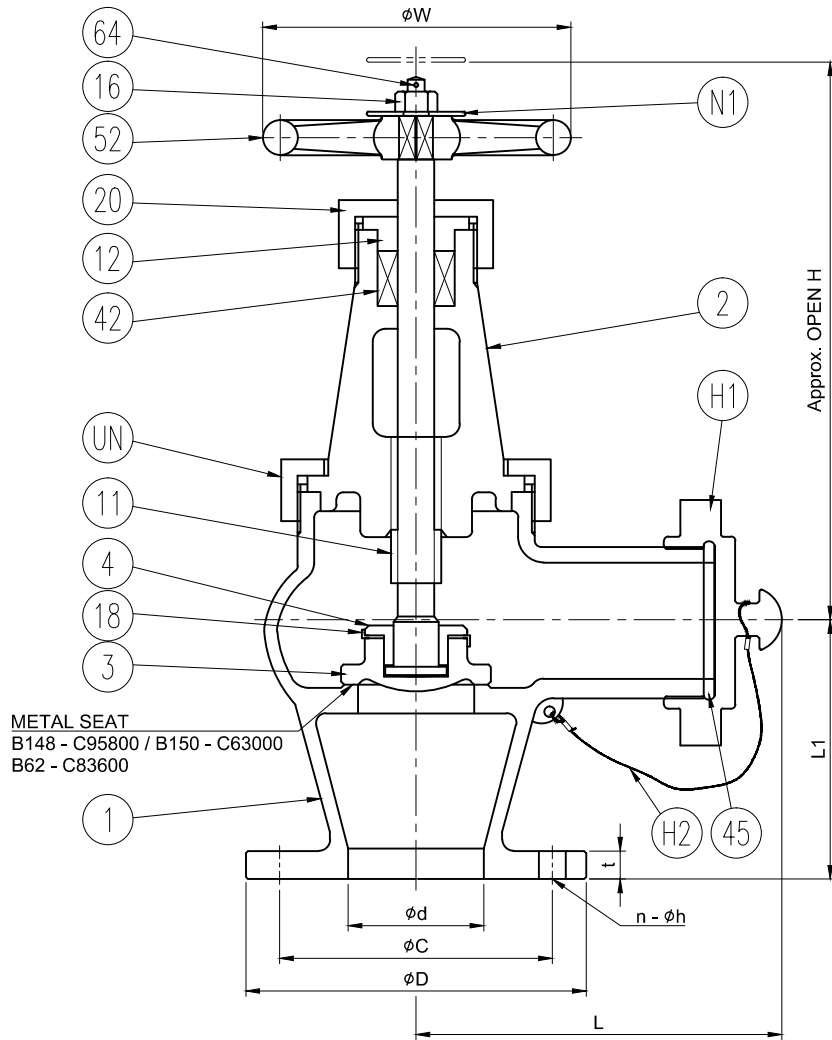

NOTES

- * Applicable Standard
- 1. Face to Face : Manufacturer's Standard
- 2. Flange Dimension : ASME B16.24
- 3. Inspection & Test : API 598
- 4. Country of Origin : Korea

UN	UNION NUT	B62 - C83600	
N1	NAME PLATE	AL / BRASS / 304 S.S	
H2	WIRE	304 / 304L S.S	
H1	CAP	B62 - C83600 / B124 - C37700	
64	SPLIT PIN	BRASS	
52	HAND WHEEL	A126 - CL.B	
45	GASKET	NBR	
42	PACKING	PTFE	
20	GLAND NUT	B124 - C37700	
18	DISC LOCK WASHER	BRASS	
16	HAND WHEEL NUT	B124 - C37700	
12	PACKING GLAND	B150 - C63000	
11	STEM	B150 - C63000	
4	DISC NUT	B150 - C63000	
3	DISC (SEAT)	B148 - C95800 / B150 - C63000	
2	BONNET	B62 - C83600	
1	BODY (SEAT)	B62 - C83600	

NO.	PART NAME	MATERIAL	REMARKS
-----	-----------	----------	---------

△					
△					

△	2020.10.27	Material Changed	J.S.LIM	S.K.CHOI	H.Y.JUNG
REV. NO.	DATE	DESCRIPTION	DRW'D BY	CHK'D BY	APP'D BY

TITLE		CAST BRONZE HOSE ANGLE VALVE			
RATING	Class 150	SIZE	See table	UNIT	mm
DRW'D BY	CHK'D BY	APP'D BY	DATE	2020.10.20	SCALE N / S
J.S.LIM	S.K.CHOI	H.Y.JUNG	TYPE	Bolted Bonnet	
			DWG. NO.	BH5A0AE - HM - WD01	
SPACE FIG NO.		△ 055401.300			

[Unit : mm]

NPS	BORE ϕd	FLANGE ASME 150Lbs FF					L1	L	H	ϕW
		ϕD	ϕC	t	n	ϕh				
1½"	38.1	125	98.6	11.2	4	16	90	120	165	125