

REVISION HISTORY			
REV	DESCRIPTION	DATE	APPROVED
	Original Drawing	15.12.2014	MGS

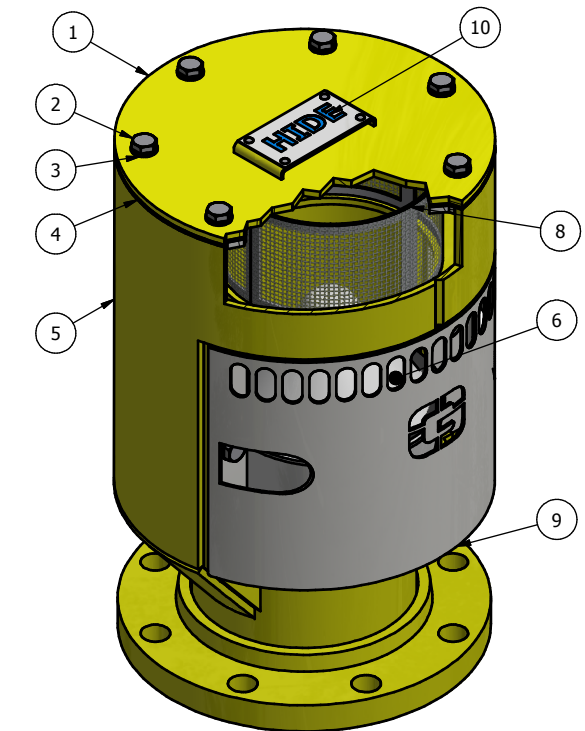

PATENT: NO/EP 2628676

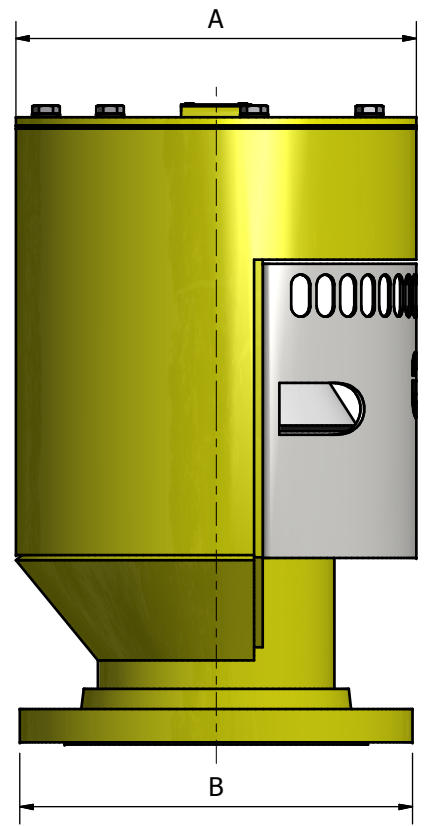
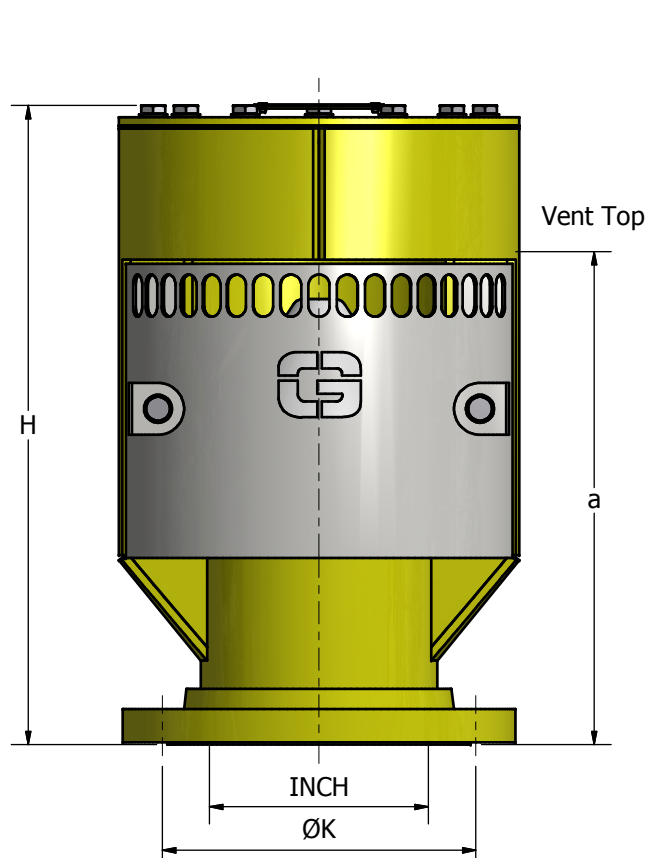
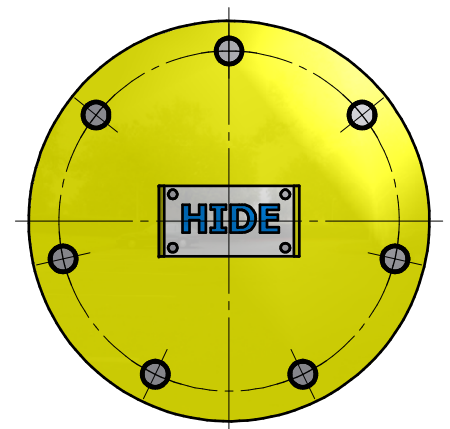

DIMENSION TABLE						
INCH	H	a	A	B	ØK	WEIGHT
1 1/2"	10,24	7,68	5,51	5,00	3,87	19.84 lbs
2"	10,24	7,68	5,51	6,00	4,75	22.04 lbs
2 1/2"	11,02	7,87	6,65	7,00	5,50	26.45 lbs
3"	12,01	8,94	7,64	7,50	6,00	30.86 lbs
4"	13,98	10,24	8,66	9,00	7,50	41.88 lbs
5"	16,54	11,89	9,84	10,00	8,50	57.32 lbs
6"	17,91	13,19	11,22	11,00	9,50	74.95 lbs
8"	20,08	14,65	13,39	13,50	11,75	105.82 lbs
10"	27,56	21,06	16,93	16,00	14,25	174.16 lbs
12"	32,52	23,90	20,47	19,00	17,00	249.12 lbs

Measurement in inch

- Item 8\* Option: Screen
- Item 7\* Option: Different flange connections available
- Approved by major classification societies

PARTLIST		
ITEM	DESCRIPTION	MATERIALE
1	TOP	HOT DIP GALVANIZED / AISI 316 / DUPLEX
2	BOLT	HOT DIP GALVANIZED / AISI 316 / DUPLEX
3	WASHER	HOT DIP GALVANIZED / AISI 316 / DUPLEX
4	GASKET	RUBBER
5	BODY	HOT DIP GALVANIZED / AISI 316 / DUPLEX
6	FLOAT DISC	ABS
7	FLANGE (*Option)	HOT DIP GALVANIZED / AISI 316 / DUPLEX
8	SCREEN (*Option)	AISI 316
9	COVER	HOT DIP GALVANIZED / AISI 316 / DUPLEX
10	LABEL	HOT DIP GALVANIZED / AISI 316 / DUPLEX

This drawing/specification is the property of JOHN GJERDE AS and must neither be used, reproduced or handed over to a third part without our permission.

[www.gjerde.com](http://www.gjerde.com)

	Date	Sign.
Drawn	15.12.2014	Maron
File	S-13359.idw	
Check		MGS
Plot	15.12.2014	MGS

**JOHN GJERDE**  
Specialists in maritime tank venting technique

Title: HIDE (Steel) General sales drawing

Draw. no. S-13626 Weight: 40,24 kg