

TECHNICAL DATA

GLOBE VALVE CAST IRON - 16K

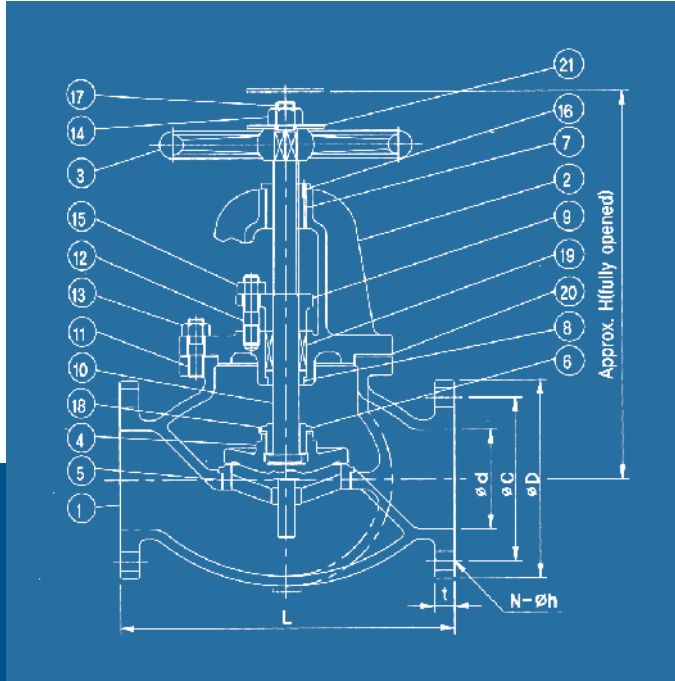

FLUID CONDITION & MAX. WORKING PRESSURE

Rating Fluid Condition	JIS 16K 50A to 200A	
	Class B	Class S
Steam up to 230°C	-	1.57(16)
Steam up to 205°C	0.98(10)	1.57(16)
Saturated steam		
Air and gas	1.57(16)	
Oil and pulsation water	1.57(16)	
Non-shock water up to 120°C	2.16(22)	

DIMENSIONS

Rating	size (mm)	ϕd (mm)	ϕD (mm)	ϕC (mm)	$N-\phi h$ (mm)	t (mm)	L (mm)	H (mm)	Weight (kg)
JIS 16K	50A	50	155	120	8-19	20	220	285	19.9
(JIS F7309)	65A	65	175	140	8-19	22	270	310	28.3
	80A	80	200	160	8-23	24	300	340	40.4
	100A	100	225	185	8-23	26	350	385	56.9
	125A	125	270	225	8-25	26	430	455	89.5
	150A	150	305	260	12-25	28	500	510	123
	200A	200	350	305	12-25	30	570	630	188

TECHNICAL FEATURES

- | | | |
|----|-------------------|--------------|
| 1 | body | cast iron |
| 2 | bonnet | cast iron |
| 3 | handwheel | cast iron |
| 4 | disc | bronze / ss |
| 5 | valve seat | bronze / ss |
| 6 | disc nut | bronze / ss |
| 7 | screw bonnet bush | bronze / ss |
| 8 | bonnet bush | bronze / ss |
| 9 | packing gland | bronze |
| 10 | stem | brass / ss |
| 11 | stud bolt | steel |
| 12 | stud bolt | steel |
| 13 | hexagon nut | steel |
| 14 | hexagon nut | steel |
| 15 | hexagon nut | steel |
| 16 | lock pin | steel |
| 17 | split pin | brass |
| 18 | disc lock washer | brass |
| 19 | packing | non asbestos |
| 20 | gasket | non asbestos |
| 21 | washer | steel |



Indicator



Screw Down Non Return (SDNR)



www.wosupply.com