

REVISIONS					
REV	DESCRIPTION	ECN	DATE	BY	APPR'D

ITEM No.	QTY	DESCRIPTION	MATERIAL	MAT'L SPEC.
1	1	BONNET, FLGD	BRONZE	ASTM B61 UNS-C92200
2	1	STEM, STOP	NI-CU	ASTM B164, CL. B
3	1	SEAT, RING	NI-CU	ASTM A494 GR M30-C
4	1	DISC, STOP	NI-CU	ASTM A494 GR M30-C
5	1	NUT, DISC	NI-CU	ASTM A494 GR M30-C
6	1	HANDWHEEL	ALUM.	ASTM-B26, ALY.B443
7	AS REQ.	STUD, BONNET	NAVAL BRASS	ASTM B21 ALLOY 464
8	AS REQ.	NUT, BONNET STUD	BRASS	2-1/2 ASTM B21 ALLOY 464
			BRASS	3,4 ASTM B16 ALLOY 360
9	1	NUT, HANDWHEEL	NAVAL BRASS	ASTM B21 ALLOY 464
10	1	GASKET	GRAPHITIC	GARLOCK 9900
11	1	PIN, DISC	NI-CU ALLY.	QQ-N-281, CL.A
12	AS REQ.	PACKING RING	TEFLON	
13	1	BODY	BRONZE	ASTM B61 UNS-C92200
14	1	GLAND	BRONZE	ASTM B61 UNS-C92200
15	1	NUT, GLAND	BRONZE	2,2-1/2,3 ASTM B61 UNS-C92200
			BRONZE	4 ASTM B62 UNS-C83600

"E" DIA. B.C.
 "F" DIA. OF HOLE
 "G" No. OF HOLE

DIM. SIZE	"A"	"B"	"C" ±1/16	"D"	"E"	"F"	"G"	"H"
2	7-7/8	5	7-1/4	6	4-3/4	3/4	4	1/2
2-1/2	9-1/2	6	8	7	5-1/2	3/4	4	9/16
3	10-1/8	7	9	7-1/2	6	3/4	4	5/8
4	12-1/2	9	11-7/8	9	7-1/2	3/4	8	11/16

DO NOT SCALE DRAWING	MACH. TOL. UNLESS OTHERWISE NOTED FRACTIONS ± 1/64 2 PLACE DEC. ± .01 3 PLACE DEC. ± .005 ANGLES ± 0'30" FINISH 125 BREAK SHARP CORNERS .010"	DEPARTMENT ENGR	 MILWAUKEE VALVE CO., INC. MILWAUKEE, WI. 53207-1519
		DRAWN BY TML DATE 10/7/05 CHECKED BY DATE APPR'D BY DATE INITIAL ECN DATE ISSUED	
THIS PRINT IS THE PROPERTY OF MILWAUKEE VALVE COMPANY, INC., AND REPRESENTS A PROPRIETARY ARTICLE IN WHICH MILWAUKEE VALVE COMPANY, INC. RETAINS ANY AND ALL PATENTS AND OTHER RIGHTS, INCLUDING EXCLUSIVE RIGHTS OF USE AND/OR MANUFACTURE AND/OR SALE. POSSESSION OF THIS PRINT DOES NOT CONVEY ANY PERMISSION TO REPRODUCE PRINT OR MANUFACTURE THE ARTICLE OR ARTICLES SHOWN THEREIN; SUCH PERMISSION TO BE GRANTED ONLY BY SPECIFIC AUTHORIZATION IN WRITING, SIGNED BY AN OFFICER OR OTHER AUTHORIZED AGENT OF MILWAUKEE VALVE CO., INC.		GLOBE STOP VALVE	
SIZE A FSCM NO. 76364 DWG NO 1063N 2" TO 4" REV -		SCALE N/A WEIGHT SHEET 1 OF 1	

REVISIONS					
REV	DESCRIPTION	ECN	DATE	BY	APPR'D

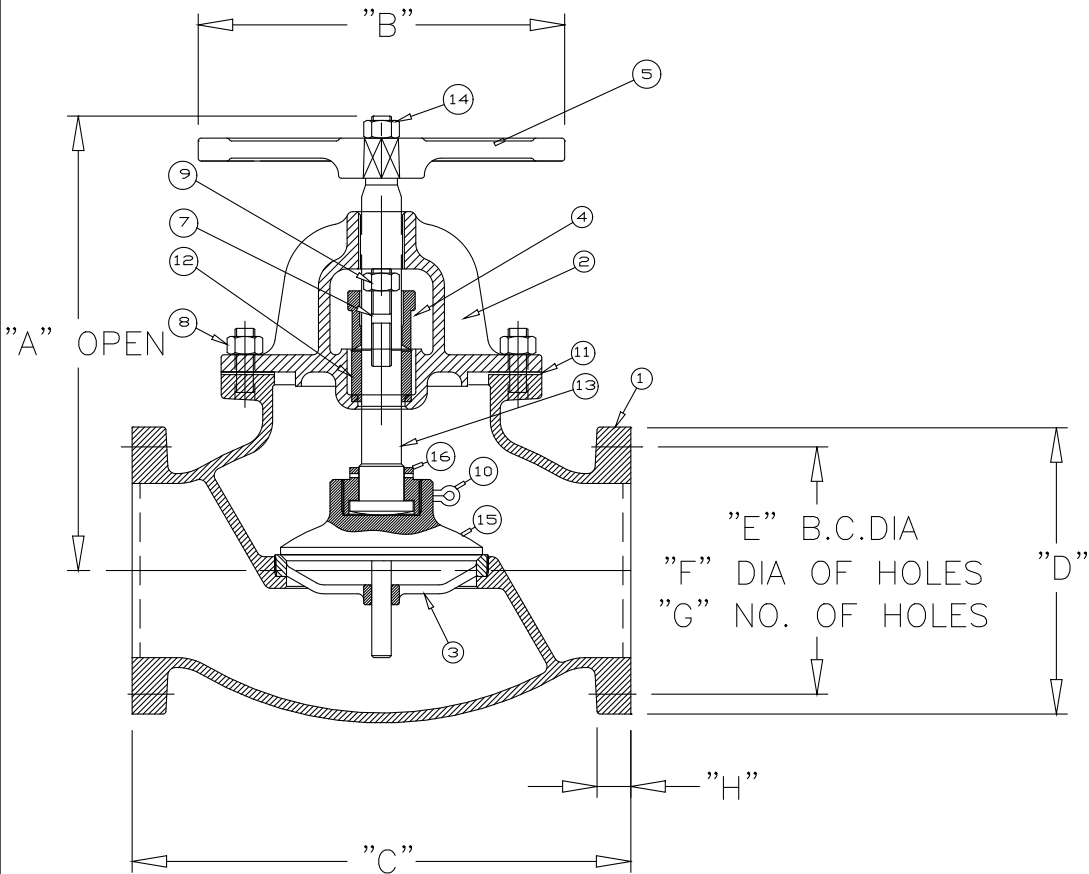

ITEM No.	QTY	DESCRIPTION	MATERIAL	MAT'L SPEC.
1	1	BODY	BRONZE	ASTM B61
2	1	BONNET, FLGD	BRONZE	ASTM B61
3	1	SEAT, RING	NI-CU ALLY.	ASTM-A494 GR. M30-H
4	1	GLAND	BRONZE	ASTM-B61
5	1	HANDWHEEL	ALUMINUM	ASTM B-26, UNS A24430
6	AS REQD	STUD, BONNET	BRONZE	ASTM B-21 UNS C46400
7	2	STUD, GLAND	BRONZE	ASTM B-21 UNS C46400
8	AS REQD	NUT, BONNET STUD	BRASS	ASTM B-16, UNS C36000
9	2	NUT, GLAND STUD	BRASS	ASTM B-16, UNS C36000
10	1	COTTER PIN	NI-CU ALLY.	QQ-N-281
11	1	GASKET	GRAPHITIC	GARLOCK 9900
12	SET	PACKING RING	TEFLON	COMMERCIAL
13	1	STEM, STOP	NI-CU ALLY	QQ-N-281
14	1	NUT, HANDWHEEL	BRASS	ASTM B-16, UNS C36000
15	1	DISC	NI-CU ALLY.	ASTM-A494, GR M30-C
16	1	DISC NUT	NI-CU ALLY.	ASTM-A494, GR M30-C

DIM. SIZE	"A"	"B"	"C" ±1/16	"D"	"E"	"F"	"G"	"H"
5	16-7/16	11	14-3/4	10	8-1/2	7/8	8	3/4
6	17-7/8	12	17-1/2	11	9-1/2	7/8	8	13/16

DO NOT SCALE DRAWING	MACH. TOL. UNLESS OTHERWISE NOTED FRACTIONS ± 1/64 2 PLACE DEC. ± .01 3 PLACE DEC. ± .005 ANGLES ± 0'30" FINISH 125 BREAK SHARP CORNERS .015	DEPARTMENT MARINE	 MILWAUKEE VALVE CO., INC. MILWAUKEE, WI. 53207-1519		
		DRAWN BY: TML CHECKED BY: APPR'D BY: INITIAL ECN: DATE ISSUED:		DATE: 3/22/02 DATE: DATE:	DRAWING TITLE
THIS PRINT IS THE PROPERTY OF MILWAUKEE VALVE COMPANY, INC. AND REPRESENTS A PROPRIETARY ARTICLE IN WHICH MILWAUKEE VALVE COMPANY, INC. RETAINS ANY AND ALL PATENTS AND OTHER RIGHTS, INCLUDING EXCLUSIVE RIGHTS OF USE AND/OR MANUFACTURE AND/OR SALE. POSSESSION OF THIS PRINT DOES NOT CONVEY ANY PERMISSION TO REPRODUCE PRINT OR MANUFACTURE THE ARTICLE OR ARTICLES SHOWN THEREIN; SUCH PERMISSION TO BE GRANTED ONLY BY SPECIFIC AUTHORIZATION IN WRITING, SIGNED BY AN OFFICER OR OTHER AUTHORIZED AGENT OF MILWAUKEE VALVE CO., INC.		GLOBE VALVE, STOP			
		SIZE A SCALE N/A	FSCM NO. 76364 WEIGHT	DWG NO 1063N 5"-6" SHEET 1 OF 1	REV -