

mm

DN	ød	L	øD	øG	øC	n-ød1	t	b	H	WT(KG)
2"	51	203	152	120.5	92	4-ø19	15.9	8.7	150.5	14
2-1/2"	64	216	178	139.5	105	4-ø19	17.6	9.5	166	21
3"	76	241	190	152.5	127	4-ø19	19.1	10.3	171	25
3-1/2"	89	267	216	178	140	8-ø19	23.9	7	190	
4"	102	292	229	190.5	157	8-ø19	23.9	11.1	204	40
5"	127	330	254	216	186	8-ø22	23.9	11.5	230	56

NOTES:

1. The valve is designed in accordance with BS1868.
2. The inspection and test of the valve shall be in accordance with API 598 .
3. The painting, protection and marking of the valve shall be in accordance with MSS SP-25.

NO.	PART NAME	QTY.	MATERIAL	REMARK
16	NAME PLATE	1	S.S.	
15	RIVET	2	S.S.	
14	SPLIT PIN	1	HPb59-1	
13	DISC NUT	1	HPb59-1	
12	NUT		ASTM A194 2H	
11	STUD		ASTM A193 B7	
10	WASHER	1	CARBON STEEL	
9	PLUG	1	CARBON STEEL	
8	GASKET	1	REINFORCED GRAPHITE	
7	WASHER	1	HPb59-1	
6	HINGE PIN	1	ASTM B505 C95400	
5	SEAT RING	1	ASTM A105N+B150 C62400	
4	HINGE	1	ASTM A216-WCB	
3	DISC	1	ASTM WCB+B150 C62400	
2	COVER	1	ASTM A105N	
1	BODY	1	ASTM A216-WCB	

Stan.	BS1868	Shell Test	3.2 MPa	Draft	
Class	150LB	Seat Test(Hyd)	2.3 MPa	Check	
Size	2~5"			Appr.	
Weight		Scale		Man. Fig.	S1RA121
Type	CAST STEEL CHECK VALVE		SPACE VALVE		
Space Figure Number: 15051B					



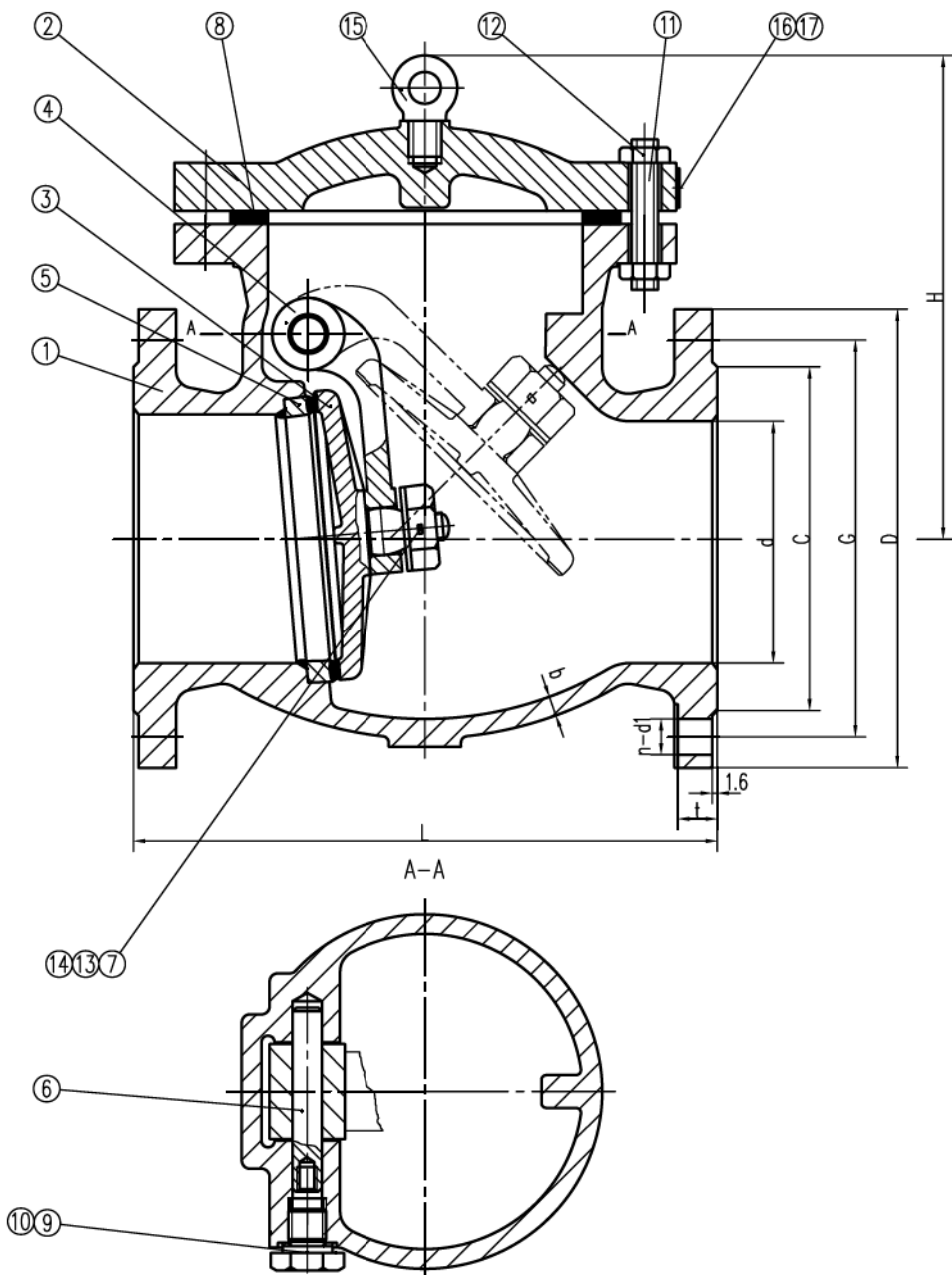

mm										
DN	ød	L	øD	øG	øC	n-ød1	t	b	H	WT(KG)
6"	152	356	279	241	216	8-ø22	25.4	11.9	296.5	71
8"	203	495	343	298.5	270	8-ø22	28.5	12.7	351.5	118

NOTES:

1. The valve is designed in accordance with BS1868.
2. The inspection and test of the valve shall be in accordance with API 598 .
3. The painting, protection and marking of the valve shall be in accordance with MSS SP-25.

NO.	PART NAME	QTY.	MATERIAL	REMARK
17	NAME PLATE	1	S.S.	
16	RIVET	2	S.S.	
15	HOOK SCREW	1	CARBON STEEL	
14	SPLIT PIN	1	HPb59-1	
13	DISC NUT	1	HPb59-1	
12	NUT		ASTM A194 2H	
11	STUD		ASTM A193 B7	
10	WASHER	1	CARBON STEEL	
9	PLUG	1	CARBON STEEL	
8	GASKET	1	REINFORCED GRAPHITE	
7	WASHER	1	HPb59-1	
6	HINGE PIN	1	ASTM B505 C95400	
5	SEAT RING	1	ASTM A105N+B150 C62400	
4	HINGE	1	ASTM A216-WCB	
3	DISC	1	ASTM WCB+B150 C62400	
2	COVER	1	ASTM A216-WCB	
1	BODY	1	ASTM A216-WCB	

Stan.	BS1868	Shell Test	3.2 MPa	Draft	
Class	150LB	Seat Test(Hyd)	2.3 MPa	Check	
Size	6~8"			Appr.	
Weight		Scale		Man. Fig.	S1RA121
Type	CAST STEEL CHECK VALVE		SPACE VALVE		
Space Figure Number: 15051B					



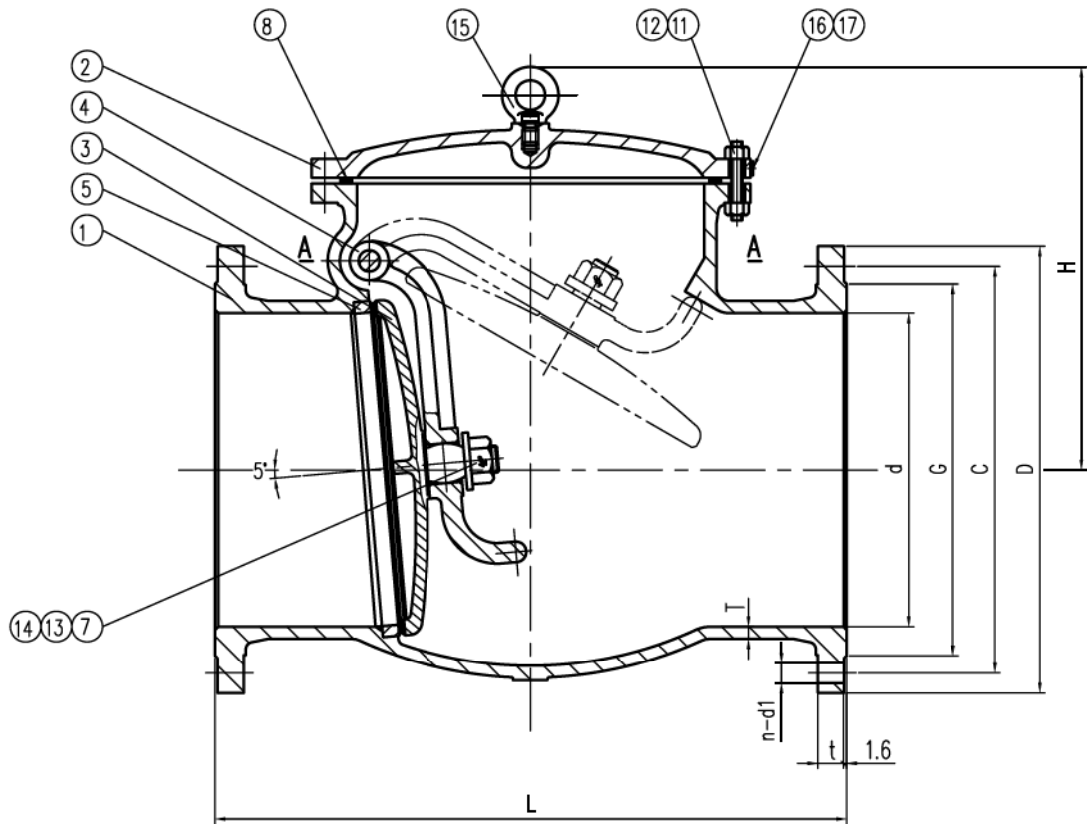

A - A

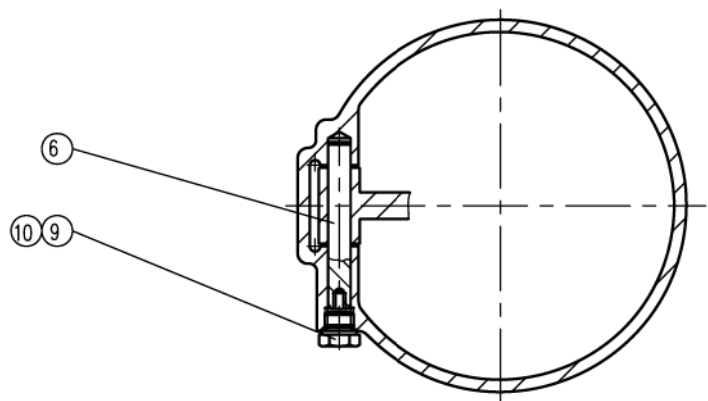

mm	DN	L	d	G	C	D	t	n-d1	H	T
	10"	622	254	324	362	406	30.3	12-25	389.5	14.3
	12"	698	305	381	432	483	31.8	12-25	437.5	15.9
	14"	787	337	413	476	533	35.1	12-29	476.5	16.7
	16"	864	387	470	539.5	597	36.6	16-29	525	17.5
	18"	978	438	533	578	635	39.7	16-32	582	18.3
	20"	978	489	584	635	698	43	20-32	627	19
	22"	1067	540	641	692	750	46	20-35	714	20
	24"	1295	591	692	749.5	813	47.8	20-35	742	20.6
	26"	1295	641	749	806.5	870	68.4	24-35	806	22

NOTES:

1. The valve is designed in accordance with BS1868.
2. The inspection and test of the valve shall be in accordance with API 598 .
3. The painting, protection and marking of the valve shall be in accordance with MSS SP-25.

NO.	PART NAME	QTY.	MATERIAL	REMARK
17	NAME PLATE	1	S.S.	
16	SCREW	2	CARBON STEEL	
15	HOOK SCREW	1	CARBON STEEL	
14	SPLIT PIN	1	HPb59-1	
13	DISC NUT	1	HPb59-1	
12	NUT		ASTM A194 2H	
11	STUD		ASTM A193 B7	
10	WASHER	1	CARBON STEEL	
9	PLUG	1	CARBON STEEL	
8	GASKET	1	REINFORCED GRAPHITE	
7	WASHER	1	HPb59-1	
6	HINGE PIN	1	ASTM B505 C95400	
5	SEAT RING	1	ASTM A105N+B150 C62400	
4	HINGE	1	ASTM A216-WCB	
3	DISC	1	ASTM WCB+B150 C62400	
2	COVER	1	ASTM A216-WCB	
1	BODY	1	ASTM A216-WCB	

Stan.	BS1868	Shell Test	3.2 MPa	Draft	
Class	150LB	Seat Test (Hyd.)	2.3 MPa	Check	
Size	10~26"			Appr.	
Weight		Scale		Man. Fig.	S1RA121
Type	CAST STEEL CHECK VALVE		SPACE VALVE		
Space Figure Number: 15051B					

