

UNIT:mm	SIZE	L	W	d	G	C	D	t	n-d1	T	H
	2"	178	200	51	92	120.5	152	15.8	4-19	5.6	352
	2-1/2"	190	200	64	105	139.5	178	17.6	4-19	5.6	380
	3"	203	250	76	127	152.5	190	19.1	4-19	5.6	415
	3-1/2"	216	250	89	140	178	216	20.6	8-19	6.4	459
	4"	229	250	102	157	190.5	229	23.9	8-19	6.4	477
	5"	254	300	127	186	216	254	23.9	8-22	7.1	546

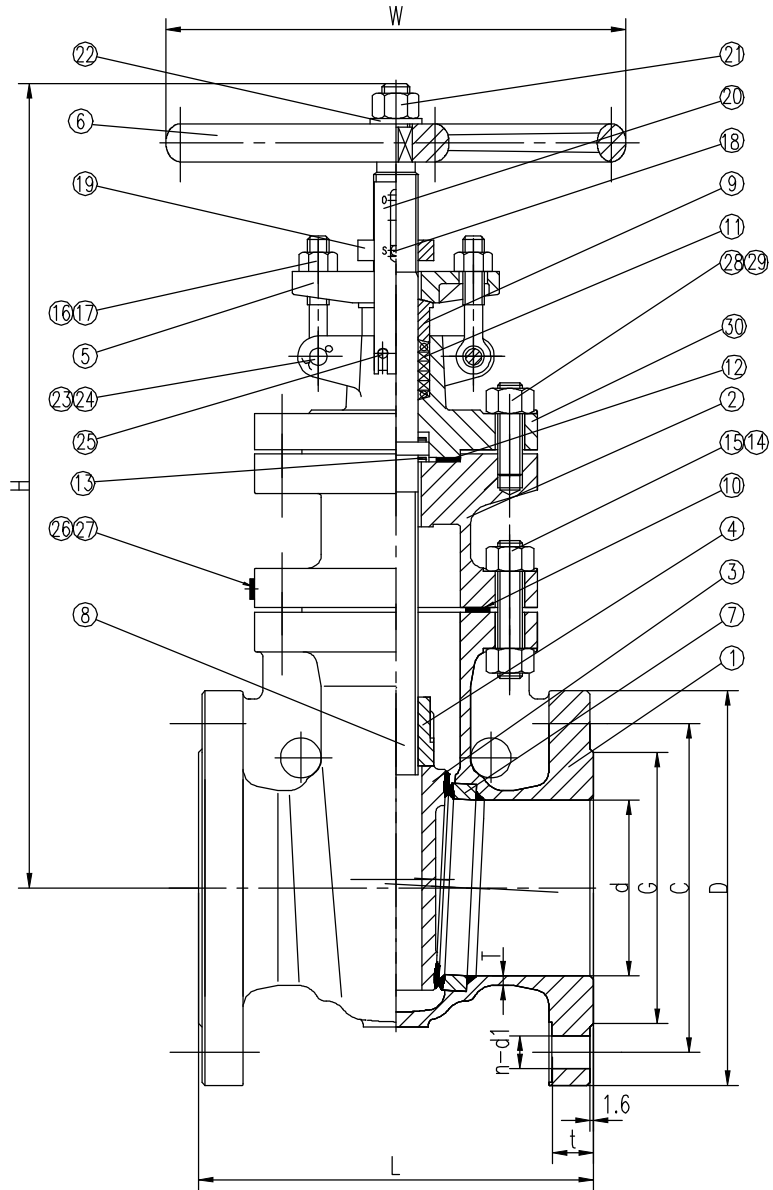

**APPLICABLE STANDARDS & TECHNICAL NOTES:**

Design: API 600  
 Inspection & Test: API 598  
 Face to Face Dimension: ASME B16.10  
 Buttleweld ends Dimension: ASME B16.5

30	YOKE	1	ASTM A216-WCB
29	NUT		ASTM A194-2H
28	STUD		ASTM A193-B7
27	NAME PLATE	1	ASTM A276-304
26	RIVET	2	ASTM A276-304
25	SCREW	2	ASTM A276-304
24	SPLIT PIN	2	ASTM A276-304
23	PIN	2	AISI 1035
22	WASHER	1	AISI 1025
21	NUT	1	AISI 1025
20	INDICATOR PLATE	1	ASTM A276-304
19	INDICATOR NUT	1	ASTM A276-304
18	INDICATOR PIN	1	ASTM A276-304
17	NUT	2	ASTM A194-2H
16	EYE BOLT	2	ASTM A193-B7
15	NUT		ASTM A194-2H
14	STUD		ASTM A193-B7
13	THRUST PLATE WASHER	2	ANSI 4140
12	GASKET	1	REINFORCED GRAPHITE
11	PACKING		John Crane C1065
10	GASKET	1	REINFORCED GRAPHITE
9	GLAND	1	ASTM A276-420
8	STEM	1	ASTM A182-F316
7	SEAT RING	2	ASTM A105N/STL.6 OVERLAY
6	HANDWHEEL	1	ASTM A536 60-40-18
5	GLAND FLANGE	1	ASTM A216-WCB
4	STEM NUT	1	ASTM A439 D-2
3	WEDGE	1	ASTM A217 WCB/316 OVERLAY
2	BONNET	1	ASTM A216-WCB
1	BODY	1	ASTM A216-WCB

No.	PART NAME	QTY	MATERIAL	REMARK
Stan.	API 600	Shell Test	3.2 MPa	Draft
Class	150 LB	Seat Test (Hyd.)	2.2 MPa	Check
Size	2"~5"	Seat Test (Air)	0.6 MPa	Appr.
Rev.	0	Man.Fig.:	GNS1R,WCB/NO.12	
Type	CAST STEEL NRS GATE VALVE			
UserFig.	SPACE Fig. 15021SS			

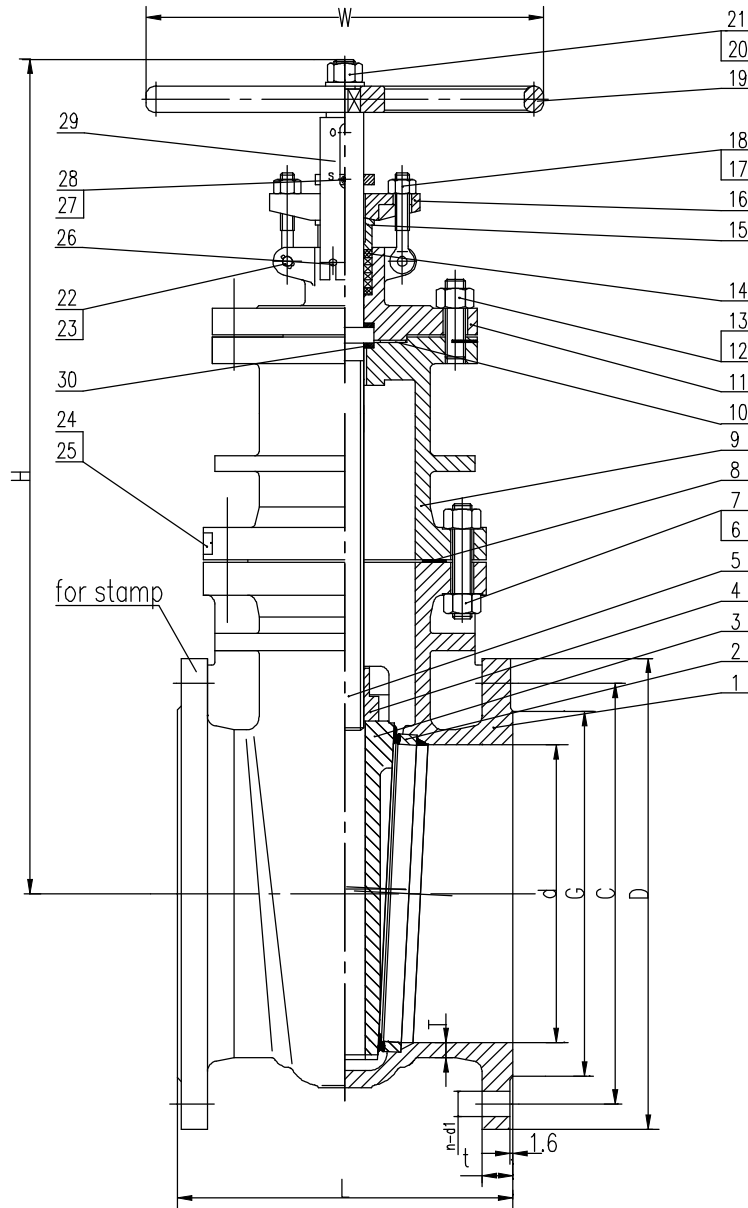

UNIT:mm	SIZE	L	W	d	G	C	D	t	n-d1	T	H
	6"	267	300	152	216	241.5	279	25.4	8-22	7.5	594
	8"	292	350	203	270	298.5	343	29	8-22	13	699
	10"	330	400	254	324	362	406	31	12-25	14.5	789
	12"	356	450	305	381	432	483	31.8	12-25	16.0	904
	14"	381	500	337	413	476	533	35	12-29	17.0	962
	16"	406	550	387	470	540	597	36.6	16-29	17.5	1127
	18"	432	600	438	533	578	635	39.7	16-32	18.5	1212
	20"	457	680	489	584	635	698	43.0	20-32	19.1	1341
	24"	508	760	591	692	749.5	813	47.8	20-35	20.6	1544

**APPLICABLE STANDARDS & TECHNICAL NOTES:**

Design: API 600 Face to Face Dimension: ASME B16.10  
 Inspection & Test: API 598 Butt welded ends Dimension: ASME B16.5

No.	PART NAME	QTY	MATERIAL	REMARK
30	THRUST PLATE WASHER	2	ANSI 4140	
29	INDICATOR PLATE	1	ASTM A276-304	
28	INDICATOR NUT	1	ASTM A276-304	
27	INDICATOR PIN	1	ASTM A276-304	
26	SCREW	2	ASTM A276-304	
25	NAME PLATE	1	ASTM A276-304	
24	RIVET	2	ASTM A276-304	
23	SPLIT PIN	2	ASTM A276-304	
22	PIN	2	AISI 1035	
21	WASHER	1	AISI 1025	
20	NUT	1	AISI 1025	
19	HANDWHEEL	1	ASTM A536 60-40-18	
18	NUT	2	ASTM A194-2H	
17	EYE BOLT	2	ASTM A193-B7	
16	GLAND FLANGE	1	ASTM A216-WCB	
15	GLAND	1	ASTM A276-420	
14	PACKING		John Crane C1065	18"-24" PTFE Neway provide
13	NUT		ASTM A194-2H	
12	STUD		ASTM A193-B7	
11	YOKE	1	ASTM A216-WCB	
10	GASKET	1	REINFORCED GRAPHITE	
9	BONNET	1	ASTM A216-WCB	
8	GASKET	1	REINFORCED GRAPHITE	
7	NUT		ASTM A194-2H	
6	STUD		ASTM A193-B7	
5	STEM	1	ASTM A182-F316	
4	STEM NUT	1	ASTM A439 D-2	
3	WEDGE	1	ASTM A216 WCB/316 OVERLAY	
2	SEAT RING	2	ASTM A105N/STL.6 OVERLAY	
1	BODY	1	ASTM A216-WCB	

Stan.	API 600	Shell Test	3.2 MPa	Draft
Class	150 LB	Seat Test (Hyd.)	2.2 MPa	Check
Size	6-24"	Seat Test (Air)	0.6 MPa	Appr.
Rev.	0	Man.Fig.:	GNS1R,WCB/NO.12	
Type	CAST STEEL NRS GATE VALVE			
UserFig.	SPACE Fig. 15021SS			