

| UNIT-mm | SIZE | L | W | d | G | C | D | t | n-d1 | T | H |
|---------|--------|-----|-----|-----|-----|-------|-----|------|------|-----|-----|
| | 2" | 178 | 200 | 51 | 92 | 120.5 | 152 | 15.8 | 4-19 | 5.6 | 352 |
| | 2-1/2" | 190 | 200 | 64 | 105 | 139.5 | 178 | 17.6 | 4-19 | 5.6 | 380 |
| | 3" | 203 | 250 | 76 | 127 | 152.5 | 190 | 19.1 | 4-19 | 5.6 | 415 |
| | 3-1/2" | 216 | 250 | 89 | 140 | 178 | 216 | 20.6 | 8-19 | 6.4 | 459 |
| | 4" | 229 | 250 | 102 | 157 | 190.5 | 229 | 23.9 | 8-19 | 6.4 | 477 |
| | 5" | 254 | 300 | 127 | 186 | 216 | 254 | 23.9 | 8-22 | 7.1 | 546 |

| APPLICABLE STANDARDS & TECHNICAL NOTES: | | | | |
|---|---------------------------|--|-----------------------------------|---|
| Design: API 600 | | Face to Face Dimension: ASME B16.10 | | |
| Inspection & Test: API 598 | | Butt-welded ends Dimension: ASME B16.5 | | |
| 30 | YOKE | 1 | ASTM A216-WCB | |
| 29 | NUT | | ASTM A194 2H | |
| 28 | STUD | | ASTM A193 B7 | |
| 27 | NAME PLATE | 1 | 304 SS | |
| 26 | RIVET | 2 | ASTM A276-304 | |
| 25 | SCREW | 2 | ISO 3506 A2-70 | |
| 24 | SPLIT PIN | 2 | ASTM A276-304 | |
| 23 | PIN | 2 | AISI 1035 | |
| 22 | WASHER | 1 | C.S. | |
| 21 | NUT | 1 | ISO 898 8 | |
| 20 | INDICATOR PLATE | 1 | 304 SS | |
| 19 | INDICATOR NUT | 1 | ASTM A276-304 | |
| 18 | INDICATOR PIN | 1 | ASTM A276-304 | |
| 17 | NUT | 2 | ASTM A194 2H | |
| 16 | EYE BOLT | 2 | ASTM A193 B7 | |
| 15 | NUT | | ASTM A194 2H | |
| 14 | STUD | | ASTM A193 B7 | |
| 13 | THRUST PLATE WASHER | 2 | ASTM A564 630 | |
| 12 | GASKET | 1 | REINFORCED GRAPHITE | |
| 11 | PACKING | | GRAPHITE | |
| 10 | GASKET | 1 | REINFORCED GRAPHITE | |
| 9 | GLAND | 1 | ASTM A276-420 | |
| 8 | STEM | 1 | ASTM B505 C95400 | |
| 7 | SEAT RING | 2 | ASTM A105N/B150 C62400 OVERLAY | |
| 6 | HANDWHEEL | 1 | Ductile Cast Iron | |
| 5 | GLAND FLANGE | 1 | ASTM A216-WCB | |
| 4 | STEM NUT | 1 | Bronze | |
| 3 | WEDGE | 1 | ASTM A216-WCB/B150 C62400 OVERLAY | |
| 2 | BONNET | 1 | ASTM A216-WCB | |
| 1 | BODY | 1 | ASTM A216-WCB | |
| No. | PART NAME | QTY | MATERIAL | REMARK |
| Stan. | API 600 | Shell Test | 3.2 MPa | Draft |
| Class | 150 LB | Seat Test (Hyd.) | 2.2 MPa | Check |
| Size | 2-5" | Seat Test (Air) | 0.6 MPa | Appr. |
| Rev. | 0 | Man.Fig.: | GNS1R V1,C00/121 | G1RA121-NRS |
| Type | CAST STEEL NRS GATE VALVE | | |  |
| UserFig. | SPACE Fig. 15021B | | | |

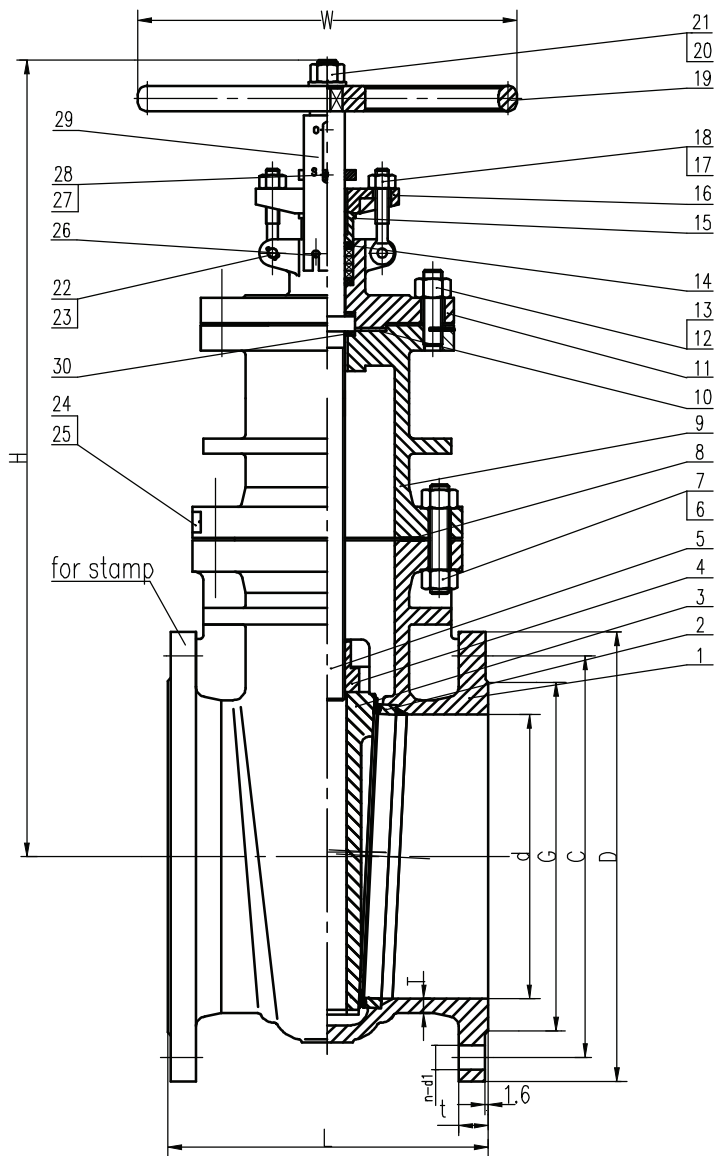

| UNIT:mm | SIZE | L | W | d | G | C | D | t | n-d1 | T | H |
|---------|------|-----|-----|-----|-----|-------|-----|------|-------|------|------|
| | 6" | 267 | 300 | 152 | 216 | 241.5 | 279 | 25.4 | 8-22 | 7.5 | 594 |
| | 8" | 292 | 350 | 203 | 270 | 298.5 | 343 | 29 | 8-22 | 13 | 699 |
| | 10" | 330 | 400 | 254 | 324 | 362 | 406 | 31 | 12-25 | 14.5 | 789 |
| | 12" | 356 | 450 | 305 | 381 | 432 | 483 | 31.8 | 12-25 | 16.0 | 904 |
| | 14" | 381 | 500 | 337 | 413 | 476 | 533 | 35 | 12-29 | 17.0 | 962 |
| | 16" | 406 | 550 | 387 | 470 | 540 | 597 | 36.6 | 16-29 | 17.5 | 1127 |
| | 18" | 432 | 600 | 438 | 533 | 578 | 635 | 39.7 | 16-32 | 18.5 | 1212 |
| | 20" | 457 | 680 | 489 | 584 | 635 | 698 | 43.0 | 20-32 | 19.1 | 1341 |
| | 24" | 508 | 760 | 591 | 692 | 749.5 | 813 | 47.8 | 20-35 | 20.6 | 1544 |

| APPLICABLE STANDARDS & TECHNICAL NOTES: | | | | |
|---|---------------------------|-------------------------------------|-----------------------------------|---|
| Design: API 600 | | Face to Face Dimension: ASME B16.10 | | |
| Inspection & Test: API 598 | | ButtWeld ends Dimension: ASME B16.5 | | |
| 30 | THRUST PLATE WASHER | 2 | ASTM A564-630 | |
| 29 | INDICATOR PLATE | 1 | 304 SS | |
| 28 | INDICATOR NUT | 1 | ASTM A276-304 | |
| 27 | INDICATOR PIN | 1 | ASTM A276-304 | |
| 26 | SCREW | 2 | ISO 3506 A2-70 | |
| 25 | NAME PLATE | 1 | 304 SS | |
| 24 | RIVET | 2 | ASTM A276-304 | |
| 23 | SPLIT PIN | 2 | ASTM A276-304 | |
| 22 | PIN | 2 | AISI 1035 | |
| 21 | WASHER | 1 | C.S. | |
| 20 | NUT | 1 | ISO 898 8 | |
| 19 | HANDWHEEL | 1 | Ductile Cast Iron | |
| 18 | NUT | 2 | ASTM A194 2H | |
| 17 | EYE BOLT | 2 | ASTM A193 B7 | |
| 16 | GLAND FLANGE | 1 | ASTM A216-WCB | |
| 15 | GLAND | 1 | ASTM A276-420 | |
| 14 | PACKING | | GRAPHITE | |
| 13 | NUT | | ASTM A194 2H | |
| 12 | STUD | | ASTM A193 B7 | |
| 11 | YOKE | 1 | ASTM A216-WCB | |
| 10 | GASKET | 1 | REINFORCED GRAPHITE | |
| 9 | BONNET | 1 | ASTM A216-WCB | |
| 8 | GASKET | 1 | REINFORCED GRAPHITE | |
| 7 | NUT | | ASTM A194 2H | |
| 6 | STUD | | ASTM A193 B7 | |
| 5 | STEM | 1 | ASTM B505 C95400 | |
| 4 | STEM NUT | 1 | Bronze | |
| 3 | WEDGE | 1 | ASTM A216-WCB/B150 C62400 OVERLAY | |
| 2 | SEAT RING | 2 | ASTM A105N/B150 C62400 OVERLAY | |
| 1 | BODY | 1 | ASTM A216-WCB | |
| No. | PART NAME | QTY | MATERIAL | REMARK |
| Stan. | API 600 | Shell Test | 3.2 MPa | Draft |
| Class | 150 LB | Seat Test (Hyd.) | 2.2 MPa | Check |
| Size | 6~24" | Seat Test (Air) | 0.6 MPa | Appr. |
| Rev. | 0 | Man.Fig.: | GNS1R V1,C00/121 | G1RA121-NRS |
| Type | CAST STEEL NRS GATE VALVE | | |  |
| UserFig. | SPACE Fig. 15021B | | | |